

# DEAD LIFT HOIST

FROM  
"THE TREND SETTERS"

# K-PAC

305 SOUTH MONROE  
P.O. BOX 2707  
HUTCHINSON, KANSAS 67501  
1-316-663-7722

- \*RECESSED SEALED BEAM LIGHTS  
IN BUMPER
- \*60,000# CAPACITY
- \*REAVING CYLINDER ROD PROTECTION
- \*PROTECTED HYDRAULIC TANK
- \*HEAT-TREAT HARDENED CAST  
REAR ROLLERS



- \*HARDENED STEEL INSIDE ROLLERS  
AND PINS, SHEAVES AND SHEAVE PINS
- \*HI-CARBON STEEL INSIDE RAIL GUIDES
- \*JIC O-RING HYDRAULIC FITTINGS

## HAULER-ENGINEERED FEATURES



ICC FOLDING BUMPER



ONE PIECE FENDER



HYDRAULIC TANK  
SITE GAUGE



SAFETY PROP

# SPECIFICATIONS

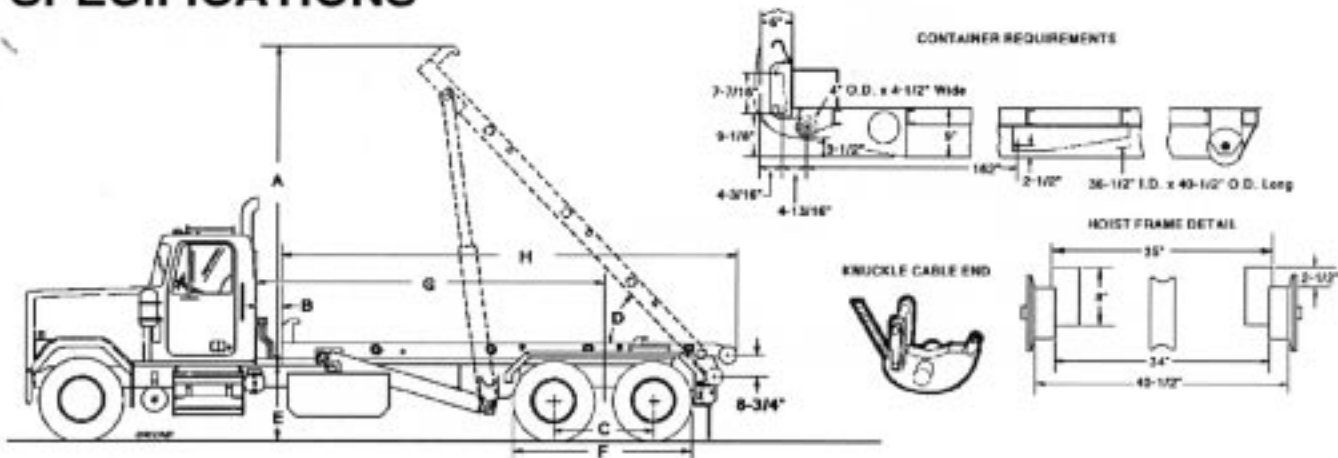

MODEL	A	B	C	D	E	F	G	H
KP60-174DLH	168"	5" - 6"	51" - 55"	47°	40" - 46" Max.	96" Max.	174"	226"

## Standard Equipment

Hoist rated capacity	50,000 lbs.
Main frame	8" x 4" x 1/2" A500 C tubing
Sub frame	4" x 2" x 1/4" A500 C tubing
Front stop	1-1/2" plate
Container lock	Automatic spring loaded
Lift cylinder shaft	2-1/2" solid steel
Rear hinge shaft	3" solid steel
Cable	7/8" x 75' (6 x 37 EXIWRC)
Cable sheaves	10" O.D. bronze-bushed sheave
Rear center sheave	8" O.D. hardened
Cable anchor	4 cable clamps
Cable end	Steel casting, knuckle-type
Rear hold down	1" plate located for std. containers
Lift cylinders	6" x 72" D.A.
Reeving cylinders	7" x 80" D.A.
Hydraulic pump	Gear type 35 GPM @ 1500 RPM
Operating pressure	1850 PSI
Hydraulic valve	2 spool 45 GPM safety bypass
Hydraulic reservoir	50 gal. 25 micron filter & screen filter
Outside rollers	4" O.D. with bronze bearing
Rear flange roller	8" O.D. hardened w/2 1/2" c-1045 shaft
Working points	Greaseable
Safety stand	Factory installed
Rear bumper	Pre-drilled bolt mount - sealed beam back-up, clearance and tail lights
Hoist-up	30 seconds approximately
Hoist down	15 seconds approximately
Cable in	46 seconds approximately
Cable out	37 seconds approximately
Container length	18" - 22"
Approximate weight	6,150 lbs.
Back-up alarm	Steam cleanable, 97 decibel, meets OSHA / state regulations

## Optional Equipment

- Drop-center cylinder mounting shaft
- Inside controls - direct connect, cable, or pneumatic
- 3 & 4 spool valve option
- Remote mount hydraulic pump - gear type 35 GPM @ 1500 RPM
- Auxiliary fold down front stops - for short containers
- "Drop-in" Stops
- Cab Guard
- Full fenders - tandem, 12 ga. steel or plastic
- Hoist-up alarm
- Tarp rack / tool box combination 20" x 16" x 48"
- PTO air operated with signal light
- \* Single - acting hydraulic line to rear
- \* Double - acting hydraulic line to rear
- \* Double - acting hydraulic line to side
- Diverter valve
- \* Note: This requires the 3 spool valve option or selector valve
- Pall filter
- Mid-body light kit



EQUIPMENT DIVISION OF  
KRAUSE CORPORATION  
P.O. BOX 2787, HUTCHINSON, KS  
67504-2787  
316-663-7722 - FAX 316-663-6943

K-PAC Equipment Division reserves the right to make changes in illustrations, specifications, and equipment in fulfilling our continued product improvement goal.